

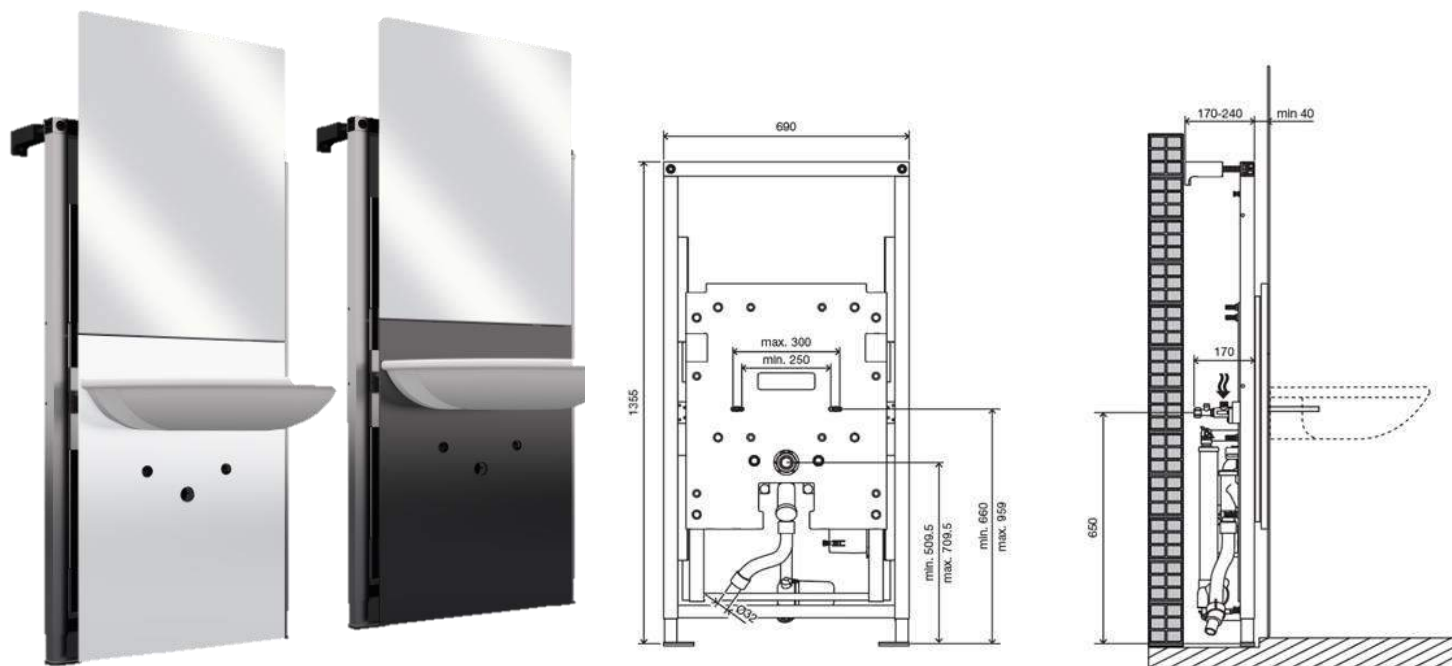

Technical Sheet

Height Adjustable Basin System (53C)



Product Identification

- Height Adjustable Basin System (53C)
- Glass White
- Glass Black

Definition and Application

- Committed to developing a safe and comfortable bathroom for all;
- LIVINGHOUSE has several solutions designed for people with reduced mobility, the elderly and children;
- Height Adjustable Basin System (53C) frame is compatible with all wall-hung washbasin;
- Ergonomic system adjustable in height by 300mm;
- Installation in resistant walls and frontal finishing in masonry and plasterboard walls;
- Available tempered glass bottom cover in black or white;
- Frame and glass are sold separately.

Technical Features

Structure

- Painted tubular with 2mm thickness, corrosion resistant
- Height adjustable from 0 to 300mm
- Easy installation with Fast Fit System
- Frame tested for 400kg load
- Mechanical adjustment system operated by one low-voltage motor, that allows height adjustment through a remote control

Millimetres measures

Technical Sheet

Height Adjustable Basin System (53C)



Accessories

- 1 Mirror
- 1 Wood panel 564x690mm
- 4 G ½" stop valve
- 2 flexible hoses 1/2Fx3/8Fx500
- 2 Stop valve 1/2x3/8
- 1 Protection sponge for washbasin
- 1 Discharge pipe PVC ¼" EN1329
- 1 Hidden Siphon 1/4" connections
- 1 Flexible outlet pipe ø32
- 1 Remote control
- 1 Electric engine

Fixing the structure to the wall and floor

- 4 Galvanized screws M8x60
- 4 Galvanized washers M8 DIN 9021
- 4 Bushing for metal structure
- 2 Fast Fit fixing

Fixing accessories for washbasin mounting on the structure:

- 2 Threaded rods M12
- 2 Nuts M12
- 2 Protection for threaded rod
- 2 Protection cover
- 2 Toilet centring washer
- 2 Washers Zn ø 34

Motor

- Power supply: 220V/110 (50/60 HZ)
- Power source: 350 Watt
- Insulation: IP66
- Movement velocity: 28mm/s
- Push power: 6000N (around 600Kgf)
- Traction power: 3000N (around 400Kgf)
- Limit switch

Warranty

Millimetres measures

Technical Sheet

Height Adjustable Basin System (53C)



Structure

- Ten (10) years warranty according to the general selling terms, starting from the purchase date of the product
- If the product is not correctly installed the warranty is not valid

Electronical components

- Two (2) years warranty according to the general selling terms, starting from the purchase date of the product
- If the product is not correctly installed the warranty is not valid

Observations

- There are available similar products. For more information please consult our site www.livinghouse.co.uk