

NOUVEAU CLASSIC CERAMIC COUNTER WASH BASIN (15A)

WEIGHT 8KG
DIMENSIONS IN MM

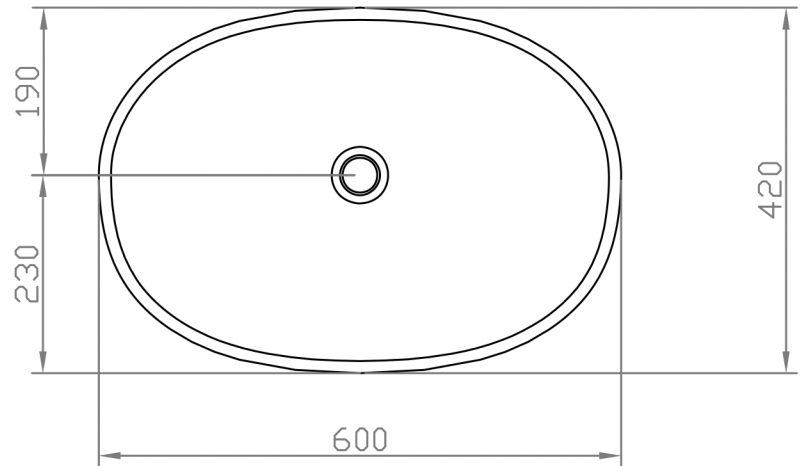

RECOMMENDED SIZE OF HOLE

