



The Surf enclosure in 10mm glass

Size Options available (to fit tray size)

Side Panel

800, 900, 1000, 1200mm

Front panel

800, 900, 1000, 1200, 1400mm

Bespoke sizes available to special order

Special finishes available to special order





For more information please contact Livinghouse

Email: sales@livinghouse.co.uk

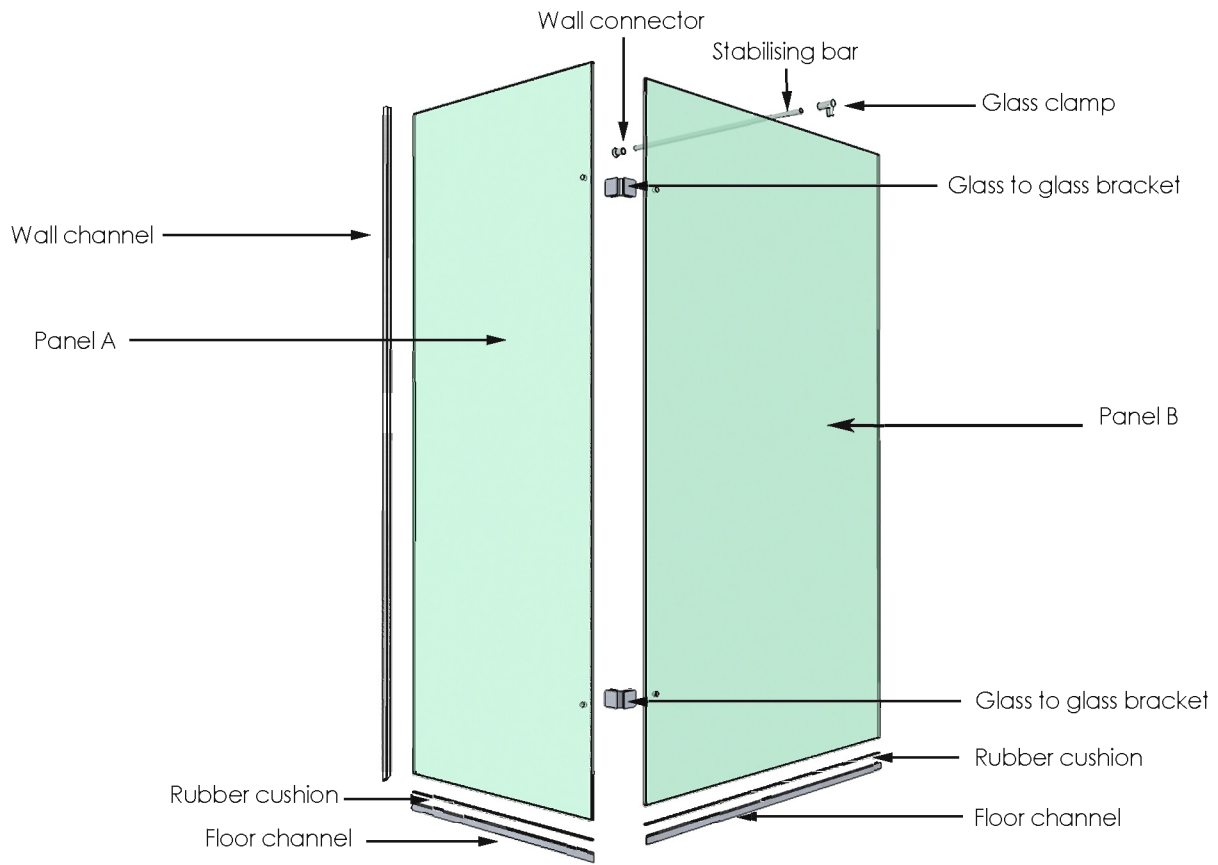
Tel: 01722 415000

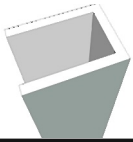
Fax: 01722 414816

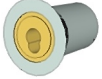

	10mm glass panel x 2		
	Wall channel	Surface recessed	
	Floor channel x 2	Surface recessed	
	Rubber cushion x 2		
	Glass to glass brackets x 2		
	Support arm inc clamp		
	Wall connector		

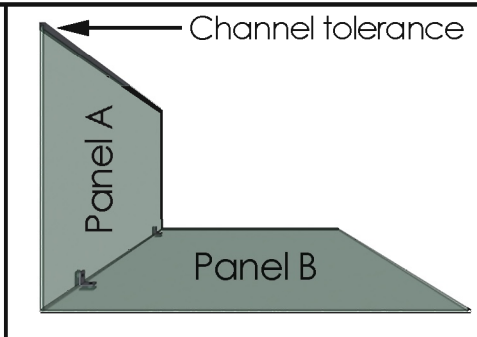
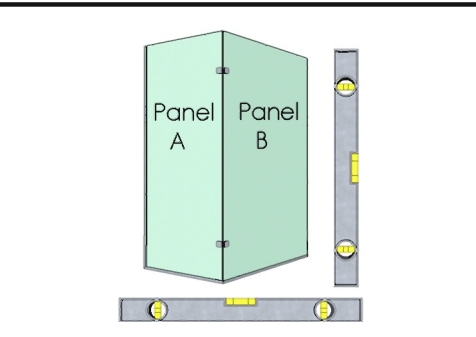

step 1
The Surf shower enclosure relies on level walls and floors for easy installation. For uneven walls and floors there are some fitting tolerances within the supplied wall channelling.

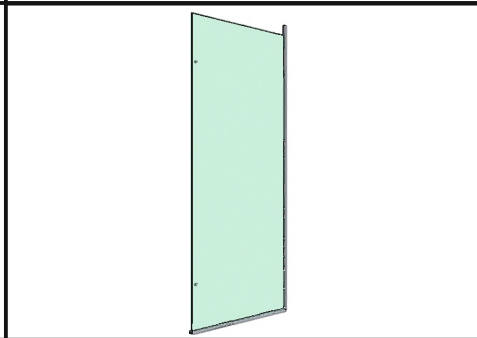
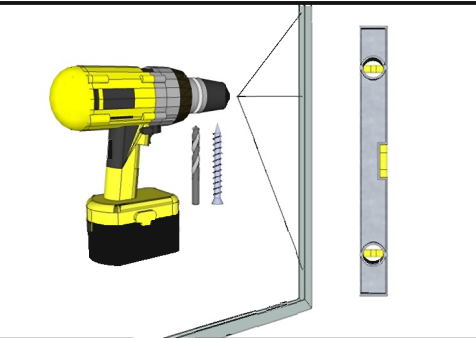

step 2
Dry fit the channelling for the wall and floor for fixed panel A using a double sided tape for the floor and screws for the wall. Ensure wall channelling is vertical. The channelling is supplied longer than required. Dry fit panel A into the channelling. Do not use silicone at this point.

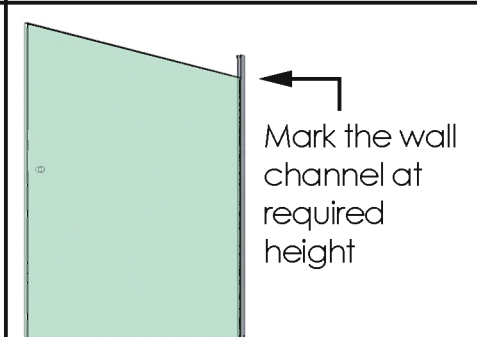
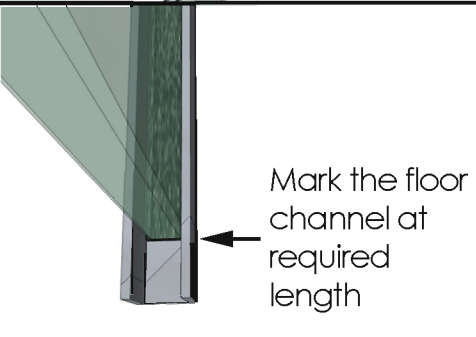

step 3
Once the panel position A has been decided within the channelling mark the floor channel with at 45 degree angle. Mark the wall channel at the correct height.

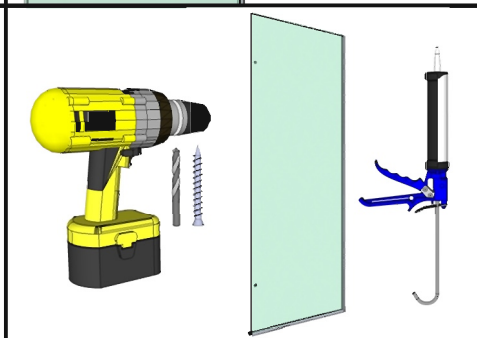
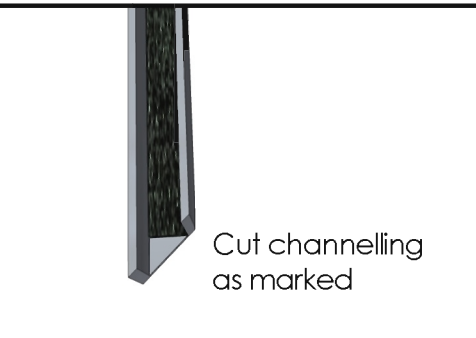

step 4
Remove Panel A from the marked channels and cut channelling as required. Final fit the channelling using silicone and screws as needed (Screws not supplied). Final fit Panel A into the installed channels using a silicone bead.

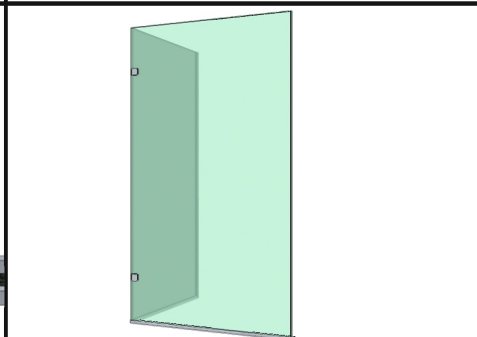

step 5
Cut the floor channelling for panel B with a 45 degree mitre to fit next to Panel A. The channelling will be supplied longer than required. Use a double sided tape to temporarily secure the channelling to the floor. Dry fit Panel B into the floor channel and fit the glass to glass brackets.

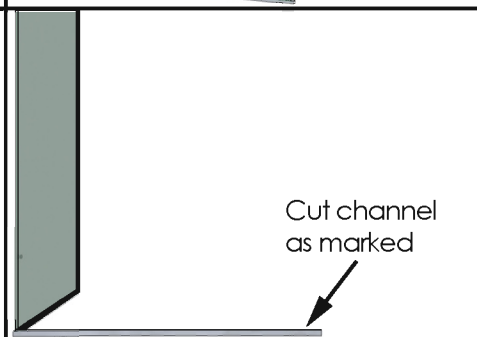
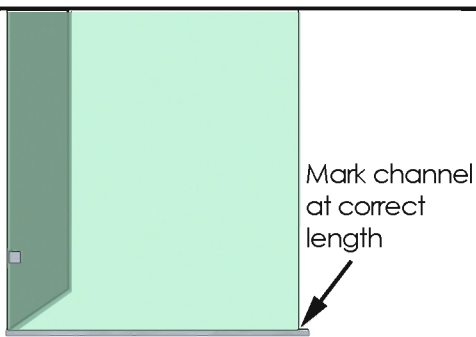

step 6
Once the 2 panels have been connected with the glass brackets mark the floor channel for panel B at the required length. Remove Panel B and cut the floor channel at the required length.



		<p>step 7 Secure the floor channel for panel B to the floor using a silicone bead. Final fix Panel B into the channelling using a silicone bead and secure the 2 panels with the glass to glass brackets.</p>
		<p>step 8 Depending on the enclosure stability expectation a support bar is supplied which can be fitted as shown. A silicone bead is also recommended for sealing between panels.</p>

Please note:

The Surf enclosure fitting instructions are assuming all walls and floor and vertical / horizontal.

The Surf enclosure is reversible so that Panel B can be either left / right hand hung.

A gasket is supplied to be fitted within the floor channelling to cushion the glass to metal contact.

Due to the amount of various wall constructions and screw fixings available, no screws or screw fixings are supplied with this partition.

Width adjustment for the Surf enclosure is minimal so it is very important that all final glass panel positions are determined before the final fixing.

Use a good quality silicone for the securing the channels /panels. Silicone is not supplied.

It is recommended that the glass panels are moved and fitted using appropriate glass suction handles which should be available from good hardware stores.